

zortrax M200

Top Choice for Reliability



3D Printer Valued by Thousands of Users

The reliable, efficient, and extremely precise Zortrax M200 has already won the hearts of thousands of users. The device's **affordable price** combined with the **high 3D print quality**, **make the Zortrax M200 3D printer a top choice among both designers and industrial companies**. Like all Zortrax products, the Zortrax M200 works within an integrated system. This is why it prints with **dimensional accuracy and repeatability that is unique to its segment**. A large workspace and a **wide selection of professional quality materials with different properties** make the Zortrax M200 a very versatile tool.

High Quality 3D Prints

precise and flawless 3D prints, always ready on time

Materials with Varied Properties

you can produce elements of your project using materials with different properties – depending on your needs

Dimensional Accuracy

elements printed separately fit together perfectly



A fully functional lens prototype printed on the Zortrax M200 using Z-ULTRAT and Z-GLASS

Precision and Ease – The Zortrax Ecosystem

Zortrax products come together to form a complete and **integrated system of professional 3D printers, compatible materials and dedicated software**. Therefore, when you choose the Zortrax M200 3D printer, you don't have to worry about the compatibility of the rest of the 3D printing set - **just open the box and start working**.

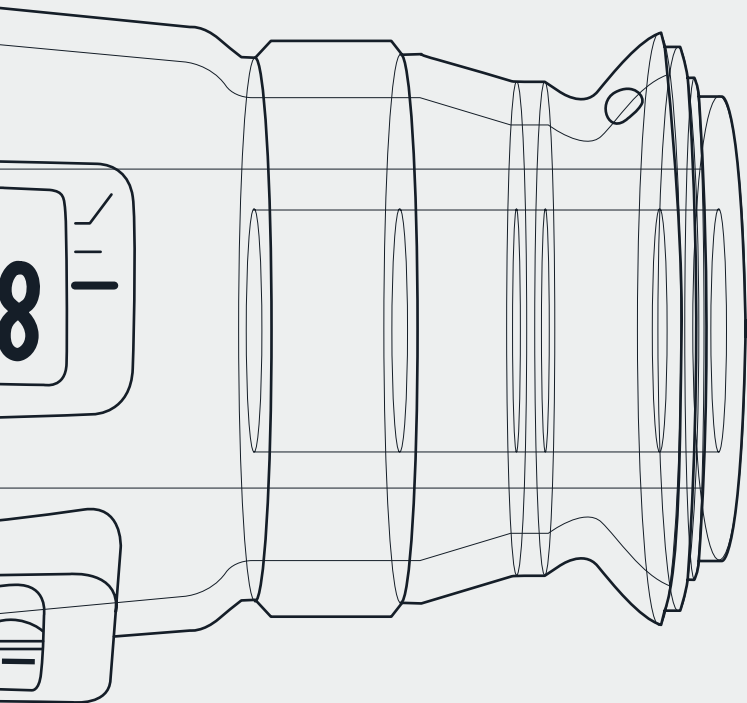

Dimensional Accuracy and Repeatability

A perfectly matched 3D printer, software and materials guarantees high quality 3D prints. **The Zortrax M200 carefully reproduces the dimensions of every 3D model** – which means that you can print detailed elements with the certainty that each copy will be identical.

From Your Idea to a 3D Reality

The intuitive 3D printing software offered by Zortrax, **Z-SUITE, works with most 3D modeling programs and reads .stl, .obj and .dxf file formats**.

It only takes a few clicks to convert your project into a real model.

Large Selection of Materials

Z-ULTRAT[®]

This versatile material allows you to create accurate prototypes the features of which are similar to products made with injection molding technology.



Z-HIPS[®]

Using this material you can create large objects that have a regular structure.



Its exceptional matte finish gives models the effect of a flawless, smooth surface.



Z-ABS[®]

This economical material, which is available in various colors, is suitable for 3D printing conceptual models, gadgets, mockups, or whatever you can imagine.



Z-GLASS[®]

With this translucent material you can prototype objects that are to be ultimately produced from glass or transparent plastic.



Z-PCABS[®]

This blend of ABS and polycarbonate (PC) will make your castings and functional prototypes durable and resistant to temperature.



Z-PETG[®]

This resistant to salts, acids and alkalis material allows you to create mechanical parts that are to be exposed to chemicals. It is also physically durable.





Your Next Best Investment

Zortrax 3D printing solutions will give your company competitive edge on the market:

- accelerating and facilitating product development
- significantly lowering prototyping costs
- increasing production flexibility
- allowing easy product customization

Discover the Zortrax M200 at www.zortrax.com

Printing

Technology	LPD – Layer Plastic Deposition is precise layer material application technology providing detailed and accurate prints
Build volume	200 x 200 x 180 mm 7.87 x 7.87 x 7.08 in 7400 cm ³
Resolution	90-400 microns
Material container	Spool
Wall thickness	Optimal: 800 microns
Resolution of single printable point	400 microns
Material diameter	1.75 mm (0.069 in)
Nozzle diameter	0.4 mm (0.015 in)
Minimum single positioning	1.5 microns
Positioning precision (X/Y)	1.5 microns
Z-axis single step	1.25 microns

Temperature

Extruder maximum temperature	380° C (716° F)
Heated platform	Yes
Platform maximum temperature	110° C (230° F)
Ambient operation temperature	20°-35° C (68°-95° F)
Storage temperature	0°-35° C (32°-95° F)

3D Printer

Support	Mechanically removed – printed from the same material as the model
Extruder	Single
Connectivity	SD card (included)
Available materials	Z-ABS, Z-ULTRAT, Z-HIPS, Z-GLASS, Z-PCABS, Z-PETG

Electrical

AC input	110/240V ~ 2 A 50/60 Hz
Power requirements	24 V DC @ 11 A
Power consumption	190W

Software

Software bundle	Z-SUITE
File types	.stl .obj .dxf
Supports	Mac OS X / Windows XP and newer versions

Physical Dimensions

Without spool	345 x 360 x 430 mm 13.6 x 14 x 16.9 in
With spool	345 x 430 x 430 mm 13.6 x 17 x 16.9 in
Shipping box	460 x 470 x 570 mm 18.1 x 18.5 x 22.4 in
Shipping weight	25 kg (55 lbs)



3D Hubs named the Zortrax M200 best Plug & Play
3D printer of 2015.

zortrax

Office:
office@zortrax.com

Sales Department:
sales@zortrax.com

Technical Support:
support@zortrax.com

zortrax.com | Find a local Reseller: **zortrax.com/resellers**

©2015 Zortrax S.A. All rights reserved.

"Zortrax", "Zortrax M200", "Zortrax Inventure", "Z-ABS", "Z-ULTRAT", "Z-HIPS", "Z-GLASS",
"Z-PCABS", "Z-PETG", "Z-ULTRAT Plus", "Z-SUITE" are registered trademarks of Zortrax S.A.